

**EPIC**  
FUTUREPROOF

# ES-809L User Manual



24 Hour A/S : [info@epic.co.kr](mailto:info@epic.co.kr)



[www.epic.co.kr](http://www.epic.co.kr)

This product should be installed by skilled installer only.  
To receive full coverage of the product warranty,  
Please do not install by yourself, For safety purposes.

# Features



## Defect-free, strong sturdy door lock

With KS & KC quality certification



## Strong & durable body components

Made to withstand heat and electric shock



## Automatic Lock / Relock / Force Lock Features

Designed to fit consumer's security needs conveniently



## "Random number" and "Multi-touch" feature for secure password use

With these features, securely authenticate your password



## Multi Password / Smart key

Password : You can register Pin number easily

Smart key : Use the smart keys included in the set right after registration

(Up to 100 keys can be registered) Other compatible cards can be registered & used



## Portable Remote Control Function (Sold separately)

Open and close the door lock easily and conveniently inside or outside by the handy remote control. (Up to 5 Remote Control can be registered)



## Dual-mode Security Feature

When the Dual-mode security is set after the user password has been registered 2nd authentication is needed and the door will open.



## Multi-level Volume Setting/Optional Mute Function

Sound can be adjusted up to 7 levels depending on user's choice



## Highly visible white light button

Highly visible white light button, for easy viewing even in dark places



## Emergency Battery Function (9V Battery)

When the battery is discharged, initialize the lock outside by using a 9V battery



## Anti-Shock / Anti-Fire / Anti-Hacking System

Aside of Anti-Shock and Anti-hacking feature, there is the Anti-Fire

feature designed for internal safety. When the inside temperature rises

Above the normal temperature and the heat sensor detects this, it will sound-off a loud alarm, and the door will automatically unlock.

# Safety Precautions

! Please do not repair  
The product by yourself

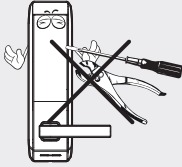

! Please check environment  
before installation



! Please read the manual  
Carefully before using

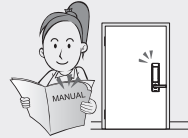

! Please do not use any  
object to operate the lock

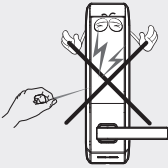

! Please change your  
Pin number periodically

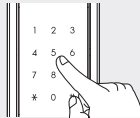

! Please do not knock or  
Apply force on the lock

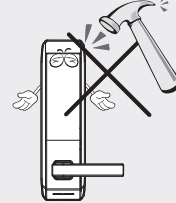

! Place only new batteries.  
Check batteries for  
leakage during insertion  
to avoid damage



! Protect the product from  
wetness & moisture



! Please replace with  
new batteries all-at-once

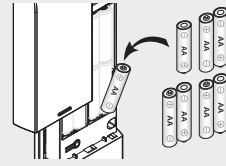

! Clean the lock with  
Clean dry cloth



! Keep the warranty card  
for A/S benefits.  
Contact seller in case  
of defect



! Please use the product  
correspondingly



# Table of Contents

01	Product Dimension & Components	05
02	Parts description	06
03	Usage	
	1 Pin number Registration	08
	2 Guest Pin number Registration	09
	3 Smart Key Registration	10
	4 Smart key Deletion	12
	5 Opening door from outside	13
	6 Closing door from outside	15
	7 Opening door from inside	15
	8 Closing door from inside	16
	9 Force lock feature	16
	10 Inside Lock Status Display Setting	17
04	Convenient Settings	
	1 Automatic & Manual Lock Setting	18
	2 Smart Key Auto/Manual Detection Setting	18
	3 Sound Mute Function	19
	4 Sound Volume Setting	19
	5 Multi-touch Security Setting	20
	6 Dual-mode Security Feature Setting	21
	7 Home Network Module Setting	22
05	Emergency Alarm Features	
	1 High Temperature Detection Alarm	23
	2 Intrusion Alarm	23
	3 Anti-Prank Alarm & 1 minute lock	23
	4 Deadbolt Error Alarm	24
	5 Replace Battery Alarm	24
	6 Emergency Mechanical Key	25
06	Troubleshooting	26
07	Consumer Protection Policy	27
08	Product Warranty	28

# 01 Product Dimension & Components

## ■ Product Dimension

Item	Description	
Installation	Normal door	40mm ~ 50mm Door Thickness
Authentication	Pin Number	4~12 Digits
	Smart Key	100 Keys can be registered
Voltage	DC 6V	LR6 1.5V AA Size Alkaline Battery 8 PCS
Emergency Battery	DC 9V	Alkaline Battery (Sold Separately)
Product Type	Non-Fire Proof, Heat Sensor, Mech.Key, Main Type Door Lock (D-NF-T-K-M)	
Heat Sensor	Temperature	72°C ± 5°C (Testing Room)
	Sensor Level	62°C ± 5°C (Normal Environment)
Material	Outbody	Al, Zn, ABS
	Inbody	Zn, ABS

## ■ RF Specification

Item	Frequency	Channel	Modulation Type	Antenna Power
RFID	13.56Mhz	1 PC	ASK	93.5dBuV/m@10
Remote Device	447.275Mhz	1 PC	FSK	10mW below

## ■ Product Components

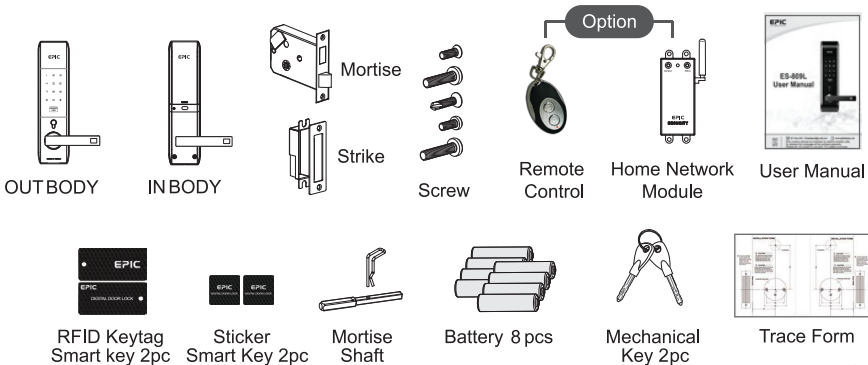

# 02 Parts Description

## ■ Outbody Parts & Function

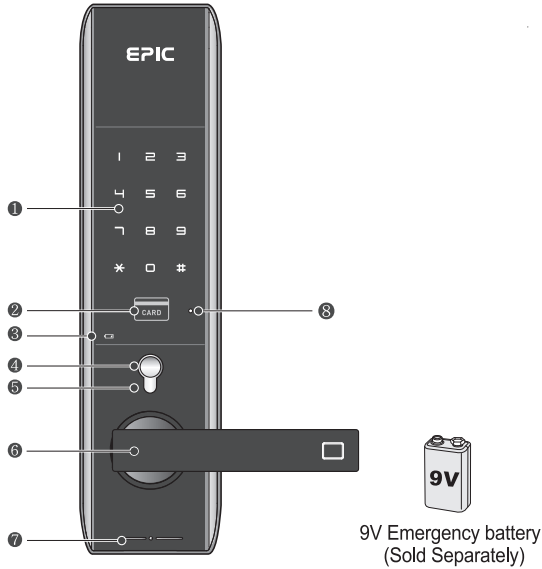

No	Parts	Function
①	Number Pad	The pin number is entered here to register or to open the door
②	RFID Card Sensor	It is the sensor where card is placed when opening the door or during card registration
③	Battery Lamp	When the battery is low it turns on along with the alarm
④	Mechanical key Hole cover	Protects the emergency mechanical key hole
⑤	Mechanical key Hole	In case of emergency the mechanical key can be inserted here to open the door
⑥	Outbody handle	It is used when opening or closing the door from outside
⑦	9V Battery Terminal	When the battery is completely discharged. Operate the lock using a 9V battery.
⑧	Reset Switch	When the product is not functioning normally, initialize the lock through the Reset switch

## 02 Parts Description

### ■ Inbody Parts & Function

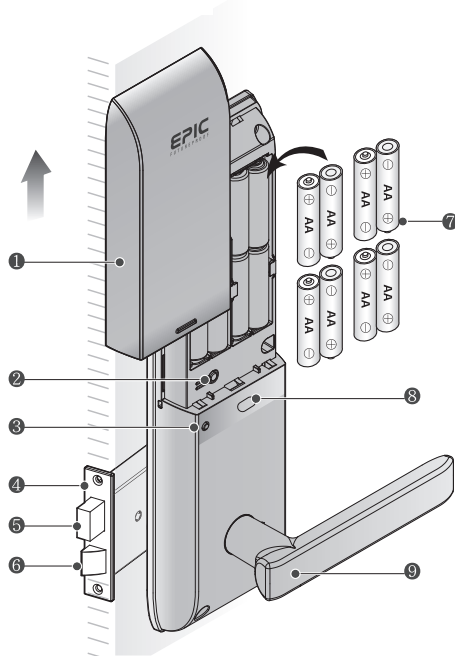

No	Parts	Function
①	Battery Cover	This is the cover that protects the battery and registration button
②	Registration Button	This is used when registering Pin, Card & Fingerprint
③	Safety button	When enabled will not allow opening of door from outside either with Pin, Card or fingerprint
④	Mortise	Is mounted at the side of the lock. It is the main locking device.
⑤	Deadbolt	It is the locking mechanism
⑥	Latch Bolt	It fix the door in place
⑦	Alkaline AA Battery	Is the main power supply of the lock
⑧	Manual Lock Button	It is used to close the door in manual locking mode
⑨	Inbody Handle	It is used to open or close the door from the inside

# 03 Usage

## 1 Pin Number Registration



### Caution

Always register pin number while door is open.  
default pin number upon purchase is [ 1, 2, 3, 4 ]

*Warning!* : Please do not forget the pin number At all times. Once forgotten you will not be able to register new pin, card or fingerprint. There is no Pin number reset.



- ① Open battery compartment cover  
Press [ Registration ] button once  
~beep sound will be heard.

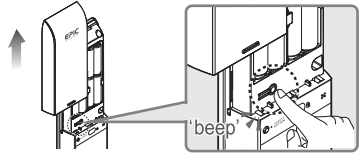

Outside

- ② Enter pin number, followed by [ \* ] button.  
Check if the number [ 1, 2, 3, 8, 0 ]  
is lighted on the number pad  
Press [ 1 ] button.

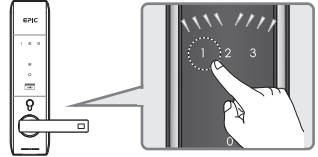

Outside

- ③ Enter Pin number to be registered 4~12 digits



Outside

- ④ Press [ \* ] button on the number pad  
A melody will be heard, and the registration  
is complete.



### Caution

Please register pin number within 10 seconds after pressing the registration button or the registration process will be cancelled  
New registration of a single pin number will delete all previously registered pin number on the system.

## 2 Guest Pin Number Registration

**⚠ Caution** THE GUEST PASSWORD IS FOR 1 TIME ENTRY ONLY

- ① Open battery compartment cover  
Press [Registration] button once  
~beep sound will be heard.

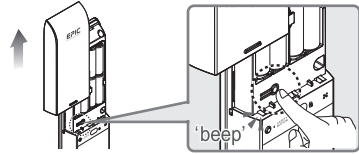

Outside

- ② Enter pin number, followed by [\*] button.  
Check if the number [ 1, 2, 3, 8, 0 ]  
are lighted on the number pad  
Press [3] button

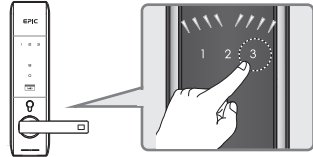

Outside

- ③ Enter New Guest Pin number to be registered 4~12 digits



Outside

- ④ Press [\*] button on the number pad  
A melody will be heard, and the registration  
is complete.



- ◆ REGISTERING MORE THAN 13 DIGITS WILL RESULT TO ERROR. NO [2] BUTTON WILL BE FLASHING
- ◆ REGISTERING LESS THAN 4 DIGITS WILL RESULT TO ERROR NO. [2] BUTTON WILL BE FLASHING
- ◆ NEW REGISTRATION WILL DELETE OLD REGISTERED PIN NUMBER
- ◆ IF NEW PIN NUMBER IS NOT REGISTERED AFTER PRESSING REGISTRATION BUTTON THE REGISTRATION MODE WILL BE CANCELLED

# 03 Usage

## 3 Smart Key Registration (Normal)

**Caution** New smart keys are registered without erasing previous registration records. Smart keys included inside the box are not registered in default. Only compatible cards can be registered and used.



- ① Open battery compartment cover  
Press [Registration] button once  
~beep sound will be heard

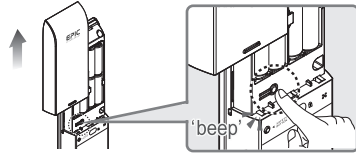

Outside

- ② Enter pin number, followed by [\*] button.  
Check if the number [ 1, 2, 3, 8, 0 ]  
are lighted on the number pad  
Press [2] button

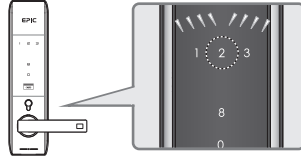

Outside

- ③ Place smart keys to be registered on the Card sensor  
(A beep sound will signal registration of each card)

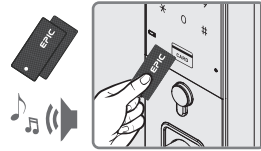

Inside

- ④ Press [Registration] button after all cards  
has been registered. And the registration  
is complete.

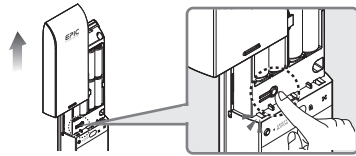

**Note** Up to 100 Smart keys can be registered. To register multiple smart keys, repeat step ③ before the number pad turns off. After all smart keys has been registered Press [Registration] button to complete.

**Caution** Place smart keys on the sensor within 10 seconds after pressing [Registration] button or the registration process will be cancelled. No more smart keys registration is possible on registering 100th smart key.

## 4 Smart Key Registration (Individual)



### Caution

The card location number should be from 001~100 and it must consist of 3 digits always.

When it is not individual card registration.

Pressing [#] button, will enable normal registration mode.

- ① Open battery compartment cover  
Press [Registration] button once  
~beep sound will be heard

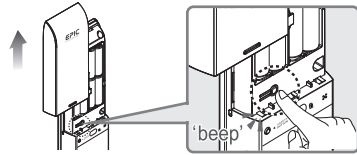

Outside

- ② Enter pin number, followed by [\*] button.

Check if the number [ 1, 2, 3, 8, 0 ]  
are lighted on the number pad  
Press [2] button

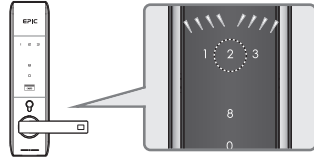

Outside

- ③ Enter the card location number consisting of  
3 digits from (001~100), followed by The [#] button.



Outside

- ④ When number pad arrow is displayed it is  
in (Smart Key Entry Standby Status).  
Place the card to be registered on the sensor.  
The beep sound will be heard, and the saved  
3 digit location number will be displayed on the number pad



Inside

- ⑤ To register additional RFID Cards,  
when all numbers on the pad is lighted, enter new location number,  
followed by [#] button, then register the new card.  
When there are no additional cards to be registered,  
Press [Registration] button to complete the registration.



## 03 Usage

### 5 Smart Key Deletion (All-at-once)

- ① Open battery compartment cover  
Press [ Registration ] button once  
~beep sound will be heard.

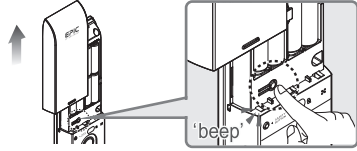

Outside

- ② Enter pin number, followed by [ \* ] button.  
Check if the number [ 1, 2, 3, 8, 0 ]  
are lighted on the number pad  
Press [ 8 ] button.

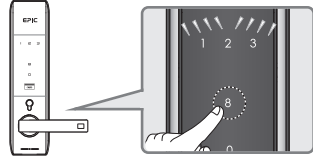

Outside

- ③ Long Press [ # ] button for 5 seconds  
When the melody is heard,  
All smart keys are deleted.

5 Sec

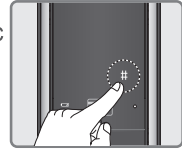

### 6 Smart Key Deletion (Individual)

- ① Open battery compartment cover  
Press [ Registration ] button once  
~beep sound will be heard.  
Enter pin number, followed by [ \* ] button.

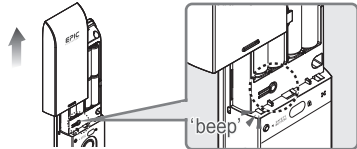

Outside

- ② Check if the number [ 1, 2, 3, 8, 0 ] are lighted on the number pad  
press [ 8 ] button, followed by [ # ] button  
Enter the registered card location number,  
followed by [ # ] button



Inside

- ③ After deletion is complete,  
all numbers are lighted on the number pad  
Additional card deletion is in standby mode.  
If there is no location number to be deleted,  
press [ Registration ] button.

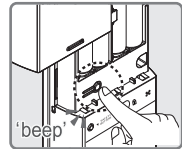

## 7 Opening Door Outside

### Method 1 Opening by Pin Number

- ① Touch the number pad

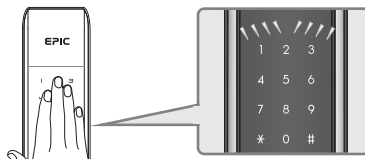

- ② Enter [Pin Number]  
And Press [ \* ] button



- ③ After the melody is heard,  
The door will open.

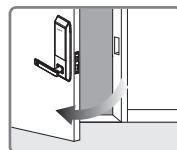

### Opening with Random Number Feature

Procedure : (Before) Enter any random number + Enter pin number + [ \* ] button.  
 (After) Enter pin number + Enter any random number + [ \* ] button.  
 Either way, when the melody is heard. The door will open.

#### Note

Random number feature is the random set of numbers that is added before or after the original pin number is entered. It is used to prevent the pin number from being exposed. Including the pin number up to 20 digits only can be entered During authentication with random number.

#### Caution

When Multi-touch feature is enabled. After entering pin number, 3 digit random number will be displayed on the screen, press the 3 numbers, followed by [\*] button and the door will open. When Multi-touch feature is disabled. The "Random Number Feature" is disabled. The "Random Number Feature" is enabled in default upon purchase. Please refer to page 20 for the setting.

# 03 Usage

## 7 Opening Door Outside

### Method 2 Opening Door by Smart Key

① During Automatic Detection Mode

Place registered smart key on sensor  
Melody will be heard and the door will open



② During Manual Detection Mode

Touch the number pad,  
check if the number pad lights up,  
place registered smart key on the sensor  
Melody will be heard and the door will open.

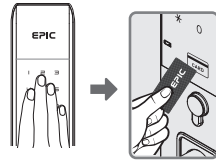

#### Note

Cards included on the set as well as compatible transportation cards, credit cards, or smart phones can be registered and used, touch the number pad, when the number pad lights up, place on the sensor and the door will open. Only compatible cards and phones can be registered and used.

## 03 Usage

### 8 Closing Door Outside

#### Method 1

#### Automatic Lock Mode

- ▶ The door will lock automatically  
After 2 seconds of closing the door  
(Refer to page 18)

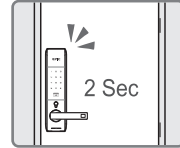

#### Method 2

#### Manual Lock Mode

- ▶ Touch the number pad  
And the door will lock  
(Refer to page 18)



### 9 Opening Door Inside



Caution

Turn the handle downward within 7 seconds  
of opening the door or the door will lock again.

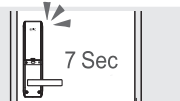

#### By turning the handle downward

- ▶ While the door is closed  
Turn the handle in downward motion  
and the door will open

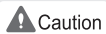
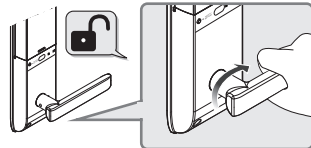

Caution

Do not install on inside-pulling doors.

## 03 Usage

### 10 Closing Door from Inside

#### Method 1 Automatic lock Mode

- ▶ The door will automatically lock  
After 2 seconds of closing the door  
(Please refer to page 18)

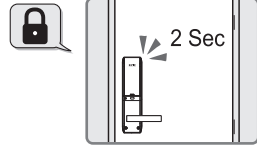

#### Method 2 Manual Lock Mode

- ▶ After closing the door,  
Press the [Manual Lock Button]  
And the door will lock  
(Please refer to page 18)

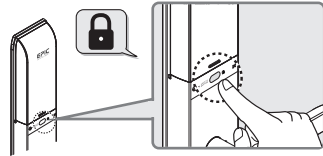

#### Note

In manual mode, when the [Manual Lock Button] is pressed, the ~beep sound will be heard to signal that the door is locked

### 11 Forced-Lock Feature

- Inside Double Lock - When enabled will not allow Pin, Card, entry from outside.

#### Setting

- ① After closing the door
- ② Press the [ Safety button ] located on the main body for 3 seconds  
melody will be heard, and setting is complete.

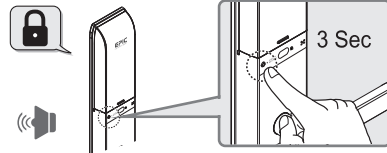

#### Cancellation

Turn the main body handle in downward motion inside, and the double lock setting will be cancelled.

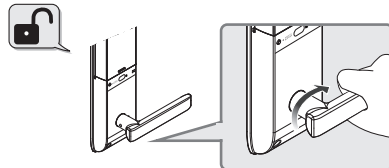

## 12 Inside Lock Status Display Setting

 **Note** During intrusion and fire alarm, the lamp will blink for 2 minutes.  
 During low battery, when the door is locking the LED lamp will be blinking.  
 ※ The Inside lock status display is enabled in default.

- ① While the door is closed.  
 Touch the number pad.

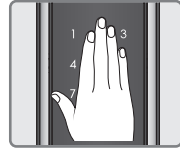

- ② Enter Pin number.  
 Press [ # ] button on the number pad.



- ③ Press [2] button to set and press [0] button to cancel.



### Manual / Automatic Lock Mode

- ▶ If the door is not locked or when the lock is set in manual lock mode and the door is not locked, the [ Safety ] button Green LED will be blinking

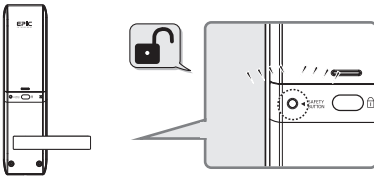

 **Note**

When the lock is set in automatic lock mode and the door is not locked.  
 The [ Safety ] button Green LED will be blinking, and ~beep sound will be heard.  
 However when the door is locked, the Green LED will not blink and the ~beep sound will not be heard.

# (Optional Settings)

## 04 Convenient Features

### 1 Automatic/Manual Lock Setting

An optional feature that lets you set the lock in Automatic and Manual Lock Mode.

#### Automatic / Manual Lock Setting While the door is partially opened

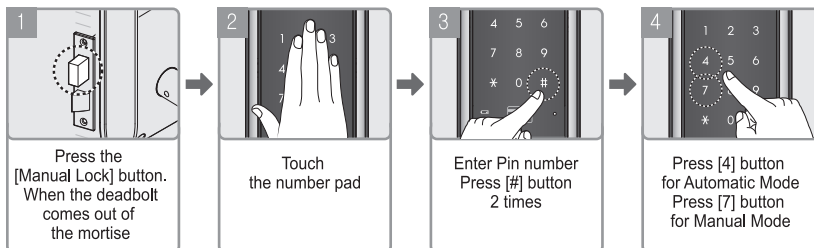

Note

Automatic Lock Mode is set in default.  
In manual lock mode, the door will not lock after closing the door,  
Instead touch the number pad outside  
or press the [Manual Lock] button inside to lock the door.

### 2 Smart Key Automatic / Manual Detection Setting

An optional feature that lets you set the smart key detection to automatic and manual mode

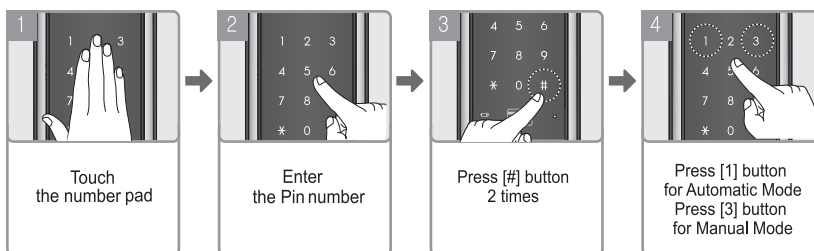

Note

- ① In Automatic Mode, Place the Smart Key on the sensor and the door will open
  - ② In manual Mode, Touch the number pad,  
Place the Smart Key on the Sensor and the door will open
- ※ Automatic Mode is enabled in default.

## (Optional Settings) 04 Convenient Features

### 3 Sound Mute Function

Regardless of the volume setting. This feature lets you mute the operation melody. This is per 1 time usage only.

#### Usage

- ① Touch the number pad,  
Press the [M] button (In mute state)

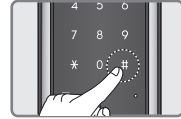

- ② Usage by Pin number :  
Enter Pin number, Press [M] button, door will open  
(Number pad will blink)



#### Note

This is 1 time usage only. The operation sound will occur on next operation

### 4 Sound Volume Setting

This feature allows the user to adjust the operation sound volume per level. (Perform while door is closed)

#### Usage

※ Sound can be adjusted up to 7 levels.



Touch  
the number pad



Enter registered  
Pin Number



Press  
[M] button



Press [3]  
or  
[6] button



#### Note

Press [3] button to increase sound.  
Press [6] button to decrease sound.  
In mute mode the number pad will blink, when you press a number.  
The volume level is set on high in default.

## (Optional Settings) 04 Convenient Features

### 5 Chime Ring Alarm Sound Settings



Note

The chime bell alarm sound will ring 3 times when the door is not closed right away. Please close the door within 10 seconds for your safety. This feature is set by default. The chime ring alarm will discharge the batteries faster. Please turn off the alarm if you want to save battery life.

- ① Touch the number pad.



- ② Enter the pin number



- ③ Press the [ # ] button



- ④ Press the number [ 2 ] to TURN ON the chime ring alarm.



- ⑤ Press the number [ 0 ] to TURN OFF the chime ring alarm.



## (Optional Settings) 04 Convenient Features

### 6 Dual-mode Security Feature Setting

The Pin number & Smart key should be registered first before setting this feature.

- ① Press [Register] button for 5 seconds  
The entire LED will light up After 3 seconds the alarm will stop  
And after 2 seconds it will be on again.
- ② Enter current user password,  
When you press [ \* ] button,  
The front panel LED will blink and light-up.

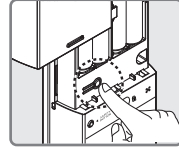

- ③ Press [ 1 ] button to Turn-Off Dual-Mode Security  
Press [ 3 ] button to Turn-On Dual-Mode Security.

During Dual-Mode Security Setting,  
when the confirmation sound is heard,  
everything will be turned-off



### HOW TO OPEN THE DOOR



PIN NUMBER



SMART CARD

#### Note

- ◆ While Dual-Mode Security Entry is on stand-by state, Other buttons cannot be entered.
- ◆ When in Security Mode Entry, please press a key within 10 seconds or it will turn off.  
When Setting Buzzer : Time Out Sound
- ◆ When the Dual-Mode Security is set After the user password has been registered  
2nd authentication is needed And the door will open.
- ◆ After entering the user password The numbers [1] [2] [3] [6] [9] [#] [0] [\*] [7] [4]  
will be displayed sequentially on the front LED When the (Tornado Shape) is displayed  
It is in the secondary authentication status.
- ◆ During 2nd authentication, use registered card and the door will open.
- ◆ The guest pin number doesn't need 2nd authentication. Just enter and the door will open.
- ◆ Even if the guest pin number is identical with user password.  
it doesn't need 2nd authentication, the door will just open (1-Time-Entry)
- ◆ During 2nd authentication, please enter pin number within 10 seconds or it will turn off.
- ◆ 2nd authentication is applied the same with the cases as :  
(Successful Authentication, Failed Authentication, 1-minute Lock)

# 04 Convenient Features

## (Optional Settings)

### 7 Home Network Module & Remote Control Setting

This feature lets you open the door remotely via home network devices and Remote Control

※ Home Network Module and Remote Control setting procedure is the same

#### Registration

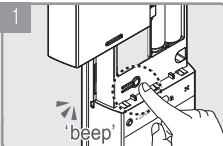

Press [Registration] button  
Enter pin number  
Followed by [\*] button  
Check if the numbers  
1, 2, 3, 8, 0 has lighted  
on the number pad

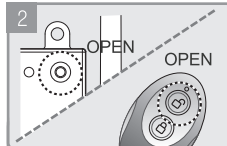

Home Network Module  
Registration  
- Press [Open] button  
  
Remote Control  
Registration  
- Press [Open] button



Press [\*] button  
on the number pad  
~beep melody will be heard  
And registration is complete



Note

For registration of additional remote control Repeat step number 2  
Up to 5 remote controls can be registered

#### Deletion

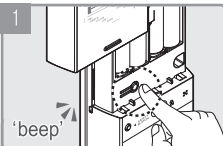

Press [Registration] button  
Enter pin number  
Followed by [\*] button  
Check if the numbers  
1, 2, 3, 8, 0 has lighted  
on the number pad



Press [0] button



Press [#] button  
for 5 seconds  
When the melody is heard  
Deletion is complete



Note

New registration of single remote control will delete previously registered ones.  
This method can be used as alternative in deleting remote control

# 05 Emergency Alarm Features

## 1 Fire Sensor Alarm

When the room temperature rises abnormally  
The heat sensor will detect this and activates an alarm

When high temperature of ( $62^{\circ}\text{C}\pm 5^{\circ}\text{C}$ ) is detected  
A loud alarm will be activated.  
And the door will automatically be unlocked.



### ! Caution

Prolonged exposure of the main body to direct sunlight can activate Fire Sensor Alarm. Even in "Double Lock" status, the door will automatically open. When temperature returns to normal. The lock will return to it's normal operation status.

## 2 Intrusion Alarm

When the lock detects forceful entry from inside or outside,  
It will activate a series of alarm

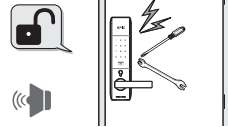

### Cancellation

Remove the batteries or enter the registered pin or card and the alarm can be cancelled.  
If temperature is high, the Fire Sensor Alarm cannot be cancelled.

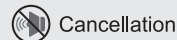

## 3 Anti-Prank Alarm & 1 Minute Lock

Improper operation of the lock outside will activate  
an alarm and the door lock will not function

5 consecutive failed Pin, Smart Key entry will activate an alarm.  
And the lock will not function for 1 minute.

5 Failed pin  
Entry

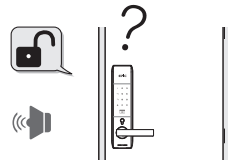
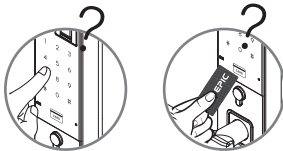

# 05 Emergency Alarm Features

## 4 Deadbolt Jammed Alarm

While opening and closing the door  
And the deadbolt has not been properly  
placed or was jammed.  
"bee~bee~bee" alarm will be activated 3 times.

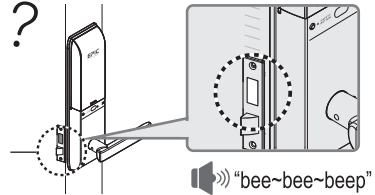

**Caution** In case the alarm continues to occur or the deadbolt does not operate normally. Please contact nearest installer in your area. Repair Cost may occur

## 5 Replace Battery Alarm





### Replacement

During normal operation, and the battery lamp is lighted, then "bee~ree~reep" sound is heard. It indicates the need for battery replacement. Please replace all battery at this time.

"bee~ree~reep"



### Emergency Battery

- 1  Purchase a 9V battery
- 2  Place battery on the 9v battery terminal
- 3  Press [\*] button
- 4  Enter Pin Number
- 5  Press [\*] button again. Melody will be heard And door will open



- Please use new batteries at all times. Do not use or mixed new batteries with old ones
- Please use batteries of same brands

## 05 Emergency Alarm Features

### 6 Emergency Key (With Emergency Key Version)

 **Note** Opening the door when the lock is not functioning normally.

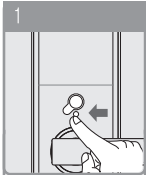

Open the emergency key hole located at the top of the front body handle by pushing cover to the right direction

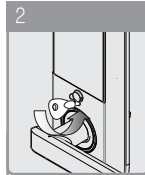

Insert the emergency key in the hole turn from right to left

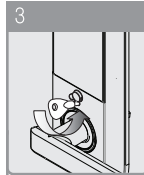

When the "tik" sound is heard and the deadbolt has moved  
Place the key in default position & remove

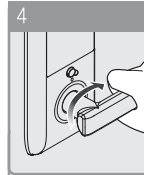

Turn the handle downward

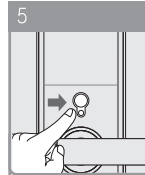

Push the emergency key hole cover to close

## 06 Troubleshooting

When the product is not functioning normally. Please check the following items below  
If the problem still occur, contact customer service center.

Problem	Solution	Ref
Power not turning-on	<ul style="list-style-type: none"> <li>- Either the battery is damaged or the battery is not inserted accurately. Check carefully.</li> <li>- Either the battery is not placed properly, or battery is discharged.</li> <li>- Try replacing all 8 batteries</li> </ul>	Page 24
Pin number cannot be changed	<ul style="list-style-type: none"> <li>- Press [Registration] button once until melody is heard</li> <li>- Check user manual for the pin number registration / changing procedure</li> </ul>	Page 08
Cannot open door After entering pin number & pressing [*] button	<ul style="list-style-type: none"> <li>- Check if you entered the correct pin number</li> <li>- Check if the number pad is on before entering pin number</li> <li>- Press [*] button to turn-on number pad then repeat entering pin number.</li> <li>- If pin number is not entered within 10 seconds authentication will be cancelled</li> </ul>	Page 08 Page 13
Cannot open door either by pin / card	<ul style="list-style-type: none"> <li>- Try using 9V battery and open the door</li> <li>- deadbolt can be defective.</li> <li>- In this case contact customer service</li> </ul>	Page 24 Page 26
During operation a ~bee~ree~reep sound is heard	<ul style="list-style-type: none"> <li>- This is the replace battery alarm, please replace all 8 batteries at this time.</li> </ul>	Page 24
Automatic lock not functioning	<ul style="list-style-type: none"> <li>- Set to Automatic Lock Mode again</li> <li>- When battery is discharged, although the melody can be heard, the lock will not function.</li> <li>- Replace all 8 batteries before use.</li> </ul>	Page 18 Page 24

A/S

When the product is not functioning please contact customer service center.

■ 24HR A/S Globalepic@gmail.com

# 07 Consumer Protection Policy

- 1) Our company follows Consumer compensation policy in conducting warranty for each A/S items.
- 2) Installation should be done by skilled installer only. In case of defect due to faulty installation the product may not receive warranty coverage.
- 3) In case of defect, please contact product vendor.

## ■ Free Service

You can get a free service, if the product fails within one year (warranty period) after purchase.

\* The warranty period for products used for commercial purposes is reduced to half of the default warranty period.

Defect Type		Coverage Details	
		Within Warranty Period	Beyond Warranty Period
Defect that occur within 10 days of purchase When defect has occurred and major repair is requested		Product Replacement	
Defect that occur within 1 month of purchase When defect has occurred and major repair is requested		Product Replacement	
Repair Valid	Same failure occur up to 3 times	Free Service	Paid Service
	Same failure occur up to 4 times	Product Replacement	Paid Service
Repair Invalid	Although parts are available But repair is not possible (Within parts retention period)	Product Replacement	After depreciation of fixed amount replacement
	Parts are unavailable But repair is not possible (Within parts retention period)	Product Replacement	After depreciation of fixed amount replacement

## ■ Paid Services

Not defected products	(1) Product not defective but requesting A/S. Check manual first to avoid A/S cost (2) Product not defective but defect caused by faulty installation (3) Pin number forgotten, and door needs breaking
Defect caused by Consumer negligence	(1) Defects caused by consumer negligence & reckless repair (2) Defects resulted from faulty installation and careless self-repair (3) Damage caused by dropping after installation
Other defects	(1) Defects caused by natural disasters (Lightning, fire, air-salt, rain, condensation) (2) Defects caused by end-life of consumable parts (Batteries) (3) Defective products without warranty certificate or adequate product purchase details. Up to 15 months free service can be provided.

## 08 Product Warranty

Product Name	ES-809L
Serial Number	
Purchase/Install Date	
Customer Name	
Telephone	
Address	

Installer Company	
Telephone	
Address	
Installer Name	

※ Please keep the warranty certificate at all times to receive adequate warranty service.

- 1) Warranty for this product will be based on the information Setforth in the warranty certificate.
- 2) The warranty period is calculated from the date of purchase. So always list the date of purchase.

### ■ Product Certification

Product Name	RFID/USN Remote device	Security System Remote Device
Certified Company name	Epic Systems Co., Ltd.	
Factory/Country	Epic Systems Co., Ltd./ South Korea	
Model Name	ES-809L	
Certification No.		
Manufacturing Date		

- 1) This is an electromagnetic device intended for usage in all areas of the home.
- 2) Product features may be developed for improvement purposes. Contents of this manual may be modified without prior notice.

# MEMO

# MEMO

---

# MEMO



■ 24 HS A/S : [info@epic.co.kr](mailto:info@epic.co.kr)



IN CASE OF EMERGENCY  
PLEASE USE THE EMERGENCY  
MECHANICAL KEY TO OPEN



No. 406, Technology Development Center, 705, Haeon-ro,  
Sangnok-gu, Ansan-si, Gyeonggi-do, Rep. of Korea

PTMP0602ONTA REV.07